

SUPPLEMENTAL INSTALLATION INSTRUCTIONS to installation and service manual 6-576.1 model HD

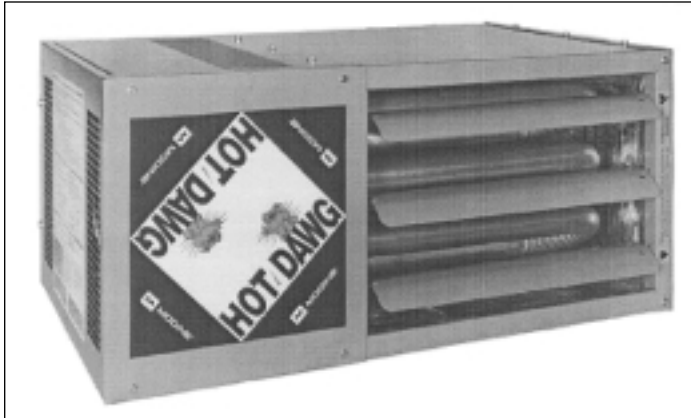

⚠️ WARNING

1. Improper installation, adjustment, alteration, service or maintenance can cause property damage, injury or death, and could cause exposure to substances which have been determined by various state agencies to cause cancer, birth defects, or other reproductive harm. Read the installation, operating, and maintenance instructions thoroughly before installing or servicing this equipment.
2. The installation and maintenance instructions in manual 6-576.1 as well as the following supplemental information must be followed to provide safe, efficient and trouble-free operation. In addition, particular care must be exercised regarding the special precautions listed on page 2 of Installation and Service Manual 6-576.1. Failure to properly address these critical areas could result in property damage or loss, personal injury, or death. These instructions are subject to any more restrictive local or national codes.



Certified for Commercial and Residential Use

FOR YOUR SAFETY

IF YOU SMELL GAS:

1. Open windows.
2. Do not touch electrical switches; do not use any telephone within the building.
3. Extinguish any open flame.
4. Immediately call your gas supplier.

IMPORTANT

The use of this manual is specifically intended for a qualified installation and service agency. A qualified installation and service agency must perform all installation and service of these appliances.

Model HD 30, 45, 60 and 75 are certified for horizontal category I venting provided the installation is in accordance with the installation instructions listed in Installation and Service Manual 6-576.1 as well as the following additional instruction for category I horizontal venting.

1. **All HD heaters installed with category I horizontal vents must be equipped with a 3 inch to 5 inch vent transition attached to the power exhaust adapter located on the unit. All other portions of the vent system shall consist of 5-inch diameter single wall vent pipe and fittings.** All joints of the venting system must be sealed with metallic tape or silastic suitable for temperatures up to 400°F. Wrap tape (2) full turns around the vent pipe joint. One continuous section of double wall vent pipe may be used with the vent system. Under no circumstances should two sections of double wall vent pipe be joined together within one vent system due to the inability to verify complete seal of inner pipes. Refer to general instructions for double wall (Type B) terminal pipe installation in installation and service manual 6-576.1 for further instructions.

2. The maximum length of the horizontal run of the vent shall be limited to the length listed in Table 2.1.
3. The vent terminal for a horizontal category I vent may be either a standard 5" diameter vent TEE, or one of two vent caps; a Gary Steel 1092 or a Breidert Type L. The maximum number of elbows, slope of the horizontal section, and minimum vertical rise from horizontal vent pipe for each configuration is listed in Table 2.1.
 - A. When using a standard vent TEE, the preferred orientation of the TEE is for the open ends of the TEE to be oriented horizontally. In this orientation, the minimum clearance to combustibles is 6 inches above the TEE to the eave. If the TEE is oriented vertically, the minimum clearance to combustibles is 27 inches above the TEE to the eave. Refer to Figure 3.1. The vent TEE should incorporate a bird screen made from corrosion resistant material. The individual strands of mesh in the bird screen must be located at least 1/4" apart.
 - B. When using a vent cap, the minimum clearance to combustibles is 6 inches above the cap to the eave. Refer to Figure 3.1.
4. When vented horizontally, maintain a 1/4" per foot rise away from the heater. Place a drain tee and clean out near the vent connector. See Figures 2.1 and 3.3. Where local authorities have jurisdiction, a 1/4" per foot downward slope is acceptable. The Condensate is allowed to drip out of the end when using a TEE terminal. See Figure 3.2. When using a vent cap with an extension, a 3/8" diameter hole is drilled in the low point of the vent by the installer exterior to the space to allow condensation drainage. See Figure 3.4.

Figure 2.1
Horizontal Category I Venting -TEE With Upward Pitch

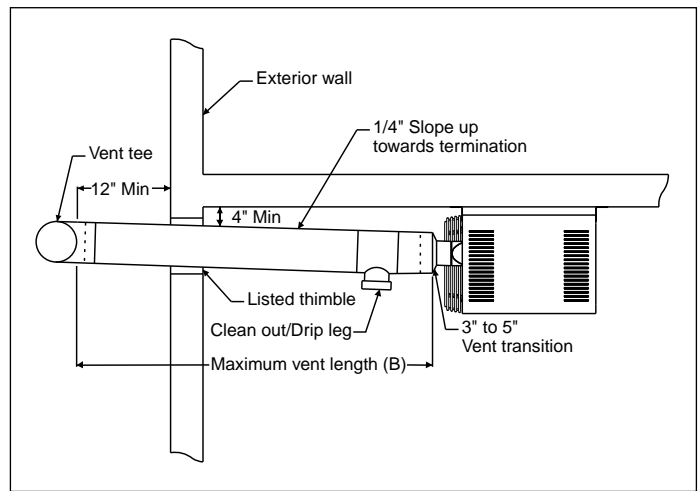

Table 2.1
Allowable Vent Configurations for Category I Horizontal Venting

Model	Vent Terminal	Maximum No. Elbows	Minimum Vertical Rise From Horizontal (in) (A)	Maximum Horizontal Vent Length (ft) (B)	Vent Diameter (in)
HD30	Vent TEE	1	0	10	5
	Vent Cap	2 ①	4 ②	10	5
HD45	Vent TEE	1	0	10	5
	Vent Cap	2 ①	12 ②	10	5
HD60	Vent TEE	1	0	10	5
	Vent Cap	2 ①	15 ②	10	5
HD75	Vent TEE	1	0	5	5
	Vent Cap	2 ①	18 ②	5	5

① One of the two allowed elbows is required to create the vent extension shown in figures 3.3 and 3.4.

② The vertical rise gained from an elbow is 4". Therefore, 4" may be subtracted from the length of vertical pipe needed in the vent extension. If the minimum vertical rise required is 4" you do not need to add a section of vertical pipe to the vent extension.

Figure 3.1
Horizontal Category I Venting - Clearance to Eave

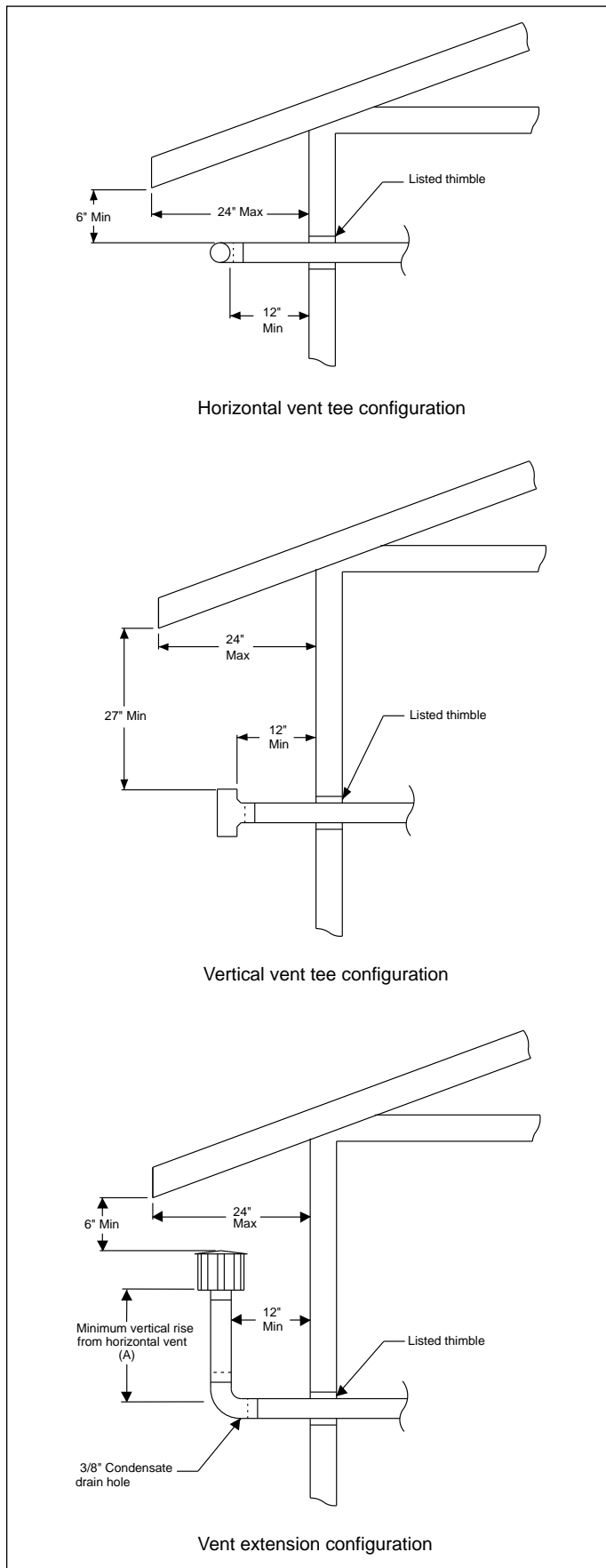

Figure 3.2
Horizontal Category I Venting - TEE With Downward Pitch

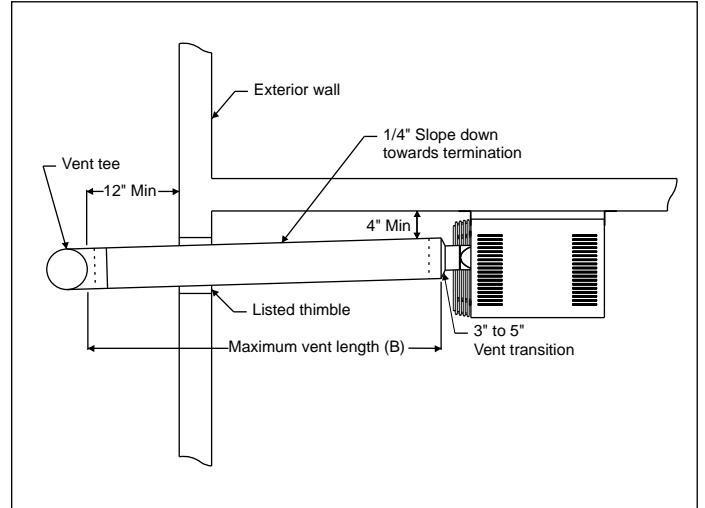

Figure 3.3
Horizontal Category I Venting - Vent Extension With Upward Pitch

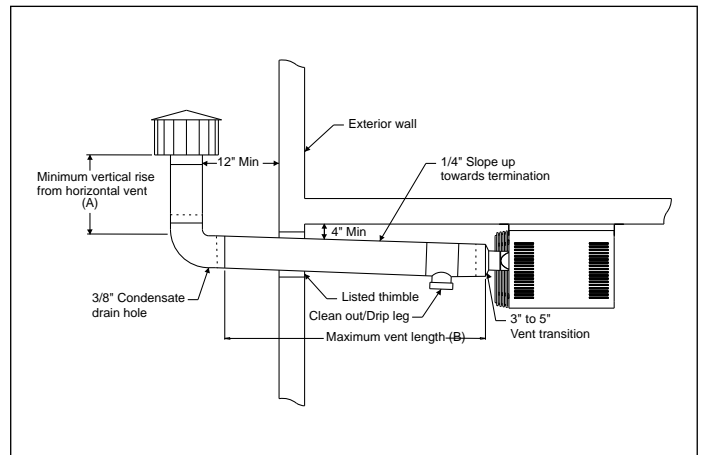
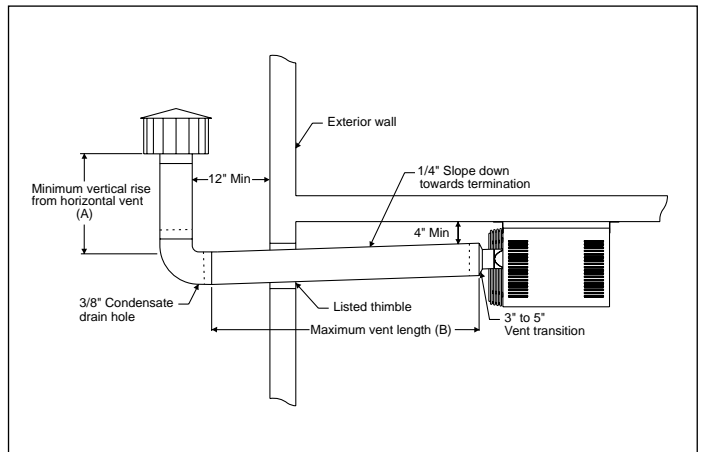

Figure 3.4
Horizontal Category I Venting - Vent Extension With Downward Pitch





Commercial HVAC&R Division • Modine Manufacturing Company • 1500 DeKoven Avenue • Racine, Wisconsin 53403-2552
Tel: 1.800.828.4328 (HEAT) • Fax: 262.636.1665 • E-mail: hvac&r@modine.com

© 1999 Modine Manufacturing Company

12/99 - 3M Litho in USA